

Driver Tool Double Coller D.T.D.C 39/22

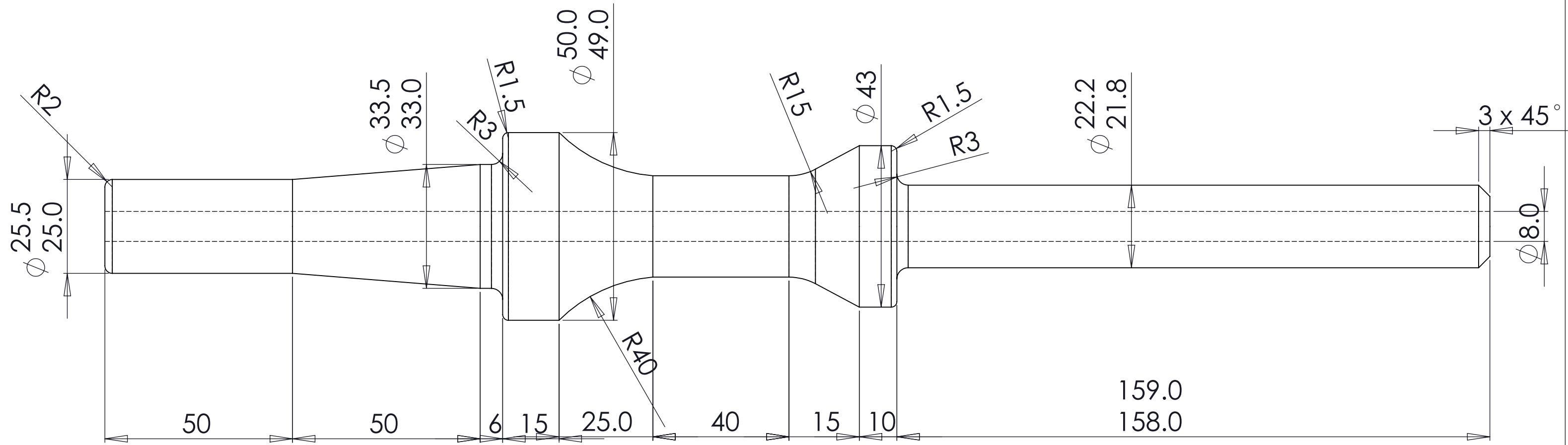

					RSC EKUSASA MINING			DRAWN		NAME	DATE	TITLE	
					THIS DRAWING IS THE COPYRIGHT OF RSC MINING & MUST NOT BE COPIED IN WHOLE OR IN PART NOR SHOULD ANY INFORMATION BE DIVULGED TO UNAUTHORISED PERSONS			CHECKED		MF	7/09/09	Driver Tool	
								APPROVED		MN	7/09/09	Double Coller	
												D.T.D.C.39 / 22	
Rev.	NOTES	DATE	SIGNED	MATERIAL					SCALE	DRAWING No.		REV.	
				E.N.36			N.T.S.			RSC 022	2		

