

Driver Tool Single Collar D.T. 39/22

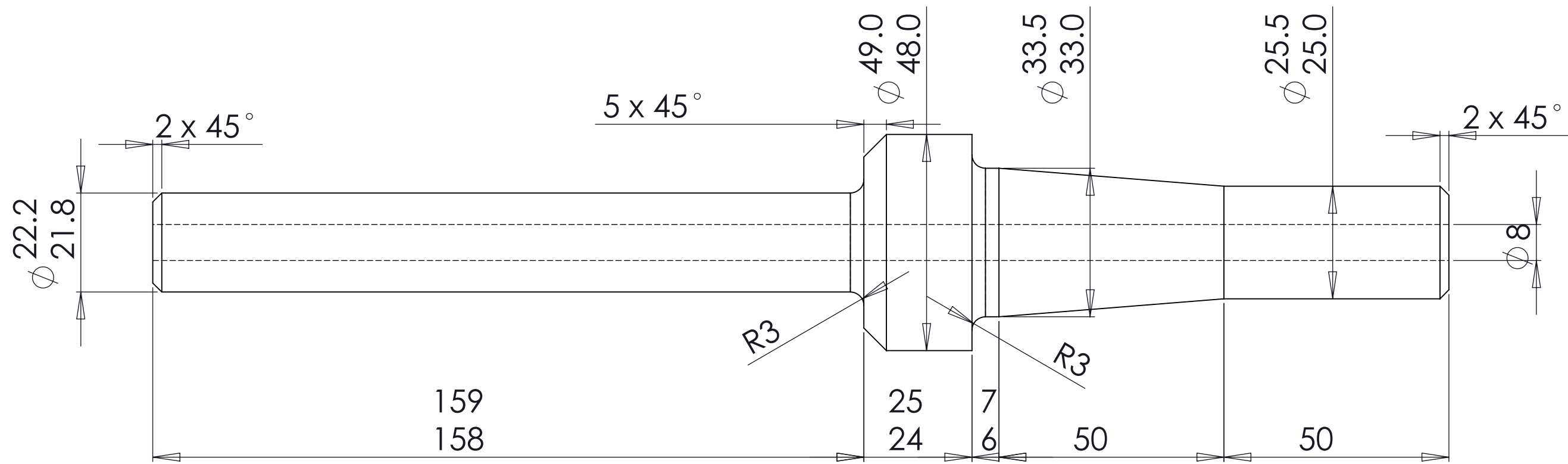

RSC EKUSASA MINING						NAME	DATE	TITLE	
2	Change main shaft to 158mm	23/03/009			DRAWN	MF	7/09/09	Driver Tool	
1	Change main shaft to 150mm	06/10/08			CHECKED	MN	7/09/09	Single Collar	
	Heat Treat to Rc 55-60	08/06/26		E.N. 36	APPROVED			D.T. 39 / 22	
Rev.	NOTES	DATE	SIGNED	MATERIAL			SCALE	DRAWING No.	REV.
					N.T.S.			RSC 023	2

THIS DRAWING IS THE COPYRIGHT OF RSC MINING & MUST NOT BE COPIED IN WHOLE OR IN PART NOR SHOULD ANY INFORMATION BE DIVULGED TO UNAUTHORISED PERSONS

